

## PAIR OF RUBBER 600 FLOOR MOUNTS



### PAIR OF RUBBER 600 MOUNTS

#### USE:

- Rubber mount: Can be used to support heavy loads.
- Each Rubber mount is equipped with a moulded-in 40 x 20 x 595mm aluminium strip, used to mount the external unit.
- The cavities located in the bottom of the Rubber mounts allow placement on a roof or on gravel without damaging roof surfaces.
- The Rubber mounts are produced from recycled tyres and provide highly effective and economical anti-vibration pads.
- Item code: AS600PBFP

#### SPECIFICATIONS:

- AS600PBFP per pair: Strapped packaging
- Weight: 12.4kg
- Supplied with screws and bolts to rail-mount the unit

#### TECHNICAL DATA:

- 2 Rubber 600 x 180 x 95 anti-vibration floor mounts. Compatible with all air conditioning unit types with a maximum weight of 400 kg.

Advantages:

Highly effective anti-vibration properties.

**4 mounting slots per Rubber mount!**

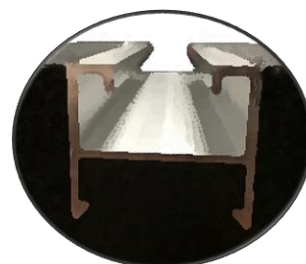
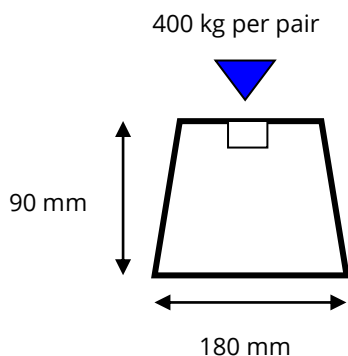

Length 600 mm

