

||||||| CENTRIFUGAL DISK FINISHING SYSTEMS TT...-A/2C |||||||



TROWAL SURFACE FINISHING

Double batch centrifugal disk finishing systems

Model range TT...-A/2C

TOP PERFORMANCE

Compared to vibratory surface finishing equipment, the Trowal Turbotron centrifugal disk finishing systems offer a more than 10 times higher grinding performance. Turbotron machines are mainly used for removal of heavy burrs and edge breaking/radiusing of small to midsize mass produced parts. However, their applications also include fine grinding, surface smoothing, polishing and even "high gloss" polishing.

THAT'S HOW IT WORKS

The centrifugal force of the rotating spinner (60 – 250 RPM) accelerates the media/work piece mass and pushes it up the inner wall of the stationary work bowl. With the diminishing kinetic energy gravity forces the media and parts to slide back onto the rotating spinner where the centrifugal force accelerates them again.

THE DOUBLE BATCH PRINCIPLE

While the system separates a first batch of finished parts from the media on an external separation unit, a second batch of raw parts is processed in the work bowl. The parallel execution of the finishing and separation function minimizes costly idle equipment times, especially during the separation process. Double batch systems are ideally suited for automated finishing processes.

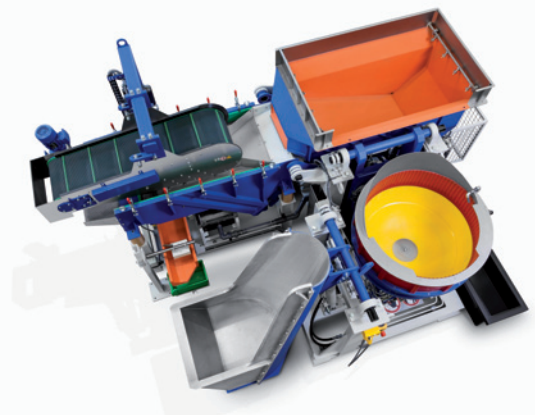
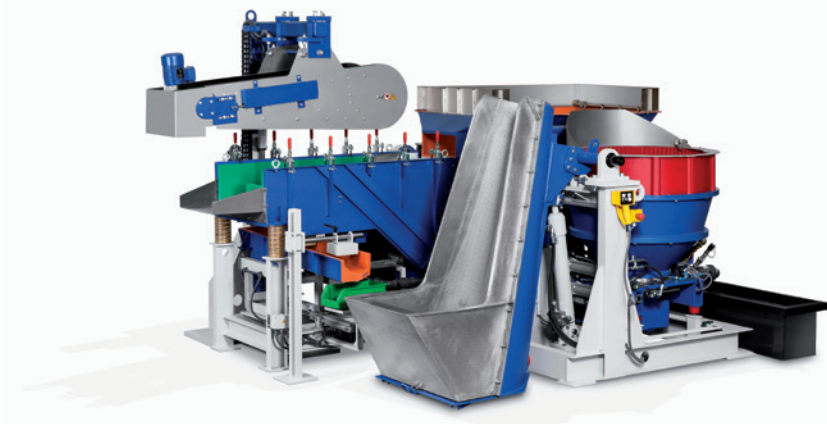

Double batch systems	TT 60-A/2C	TT 90-A/2C	TT 140-A/2C	TT 280-A/2C	TT 520-A/2C
Work bowl gross volume (l)	60	90	140	280	520
Work piece batch sizes (l)*	6-40	8-60	14-100	28-200	50-400
Work bowl material	Steel fabrication with PU lining				
Spinner drive mode	Electric				
Spinner drive power (kW)	4	4	11	15	30
Speed at 50 Hz (RPM)	213	213	179	181	145
Screening area (m2)	0.5	0.5	0.5	0.8	0.8

* Part geometry, material and risk of nicking are important for the determination of the media/work piece ratio

		A	AA	B	C	D	E	F	G	H
TT 60	A/2C*	2,100		3,100	2,700	542	ca. 830	1,085	1,212	422
	A/T**		3,100	3,100	2,700	542	ca. 830	1,085	1,212	422
TT 90	A/2C*	2,100		3,100	2,700	637	ca. 830	1,115	1,212	422
	A/T**		3,100	3,100	2,700	637	ca. 830	1,115	1,212	422
TT 140	A/2C*	2,350		3,300	3,000	740	ca. 950	1,255	1,342	493
	A/T**		3,450	3,300	3,000	740	ca. 950	1,255	1,342	493
TT 280	A/2C*	2,750		3,500	3,025	914	ca. 950	1,320	1,530	550
	A/T**		4,100	3,500	3,025	914	ca. 950	1,320	1,530	550
TT 520	A/2C*	3,000		4,000	3,400	1,000	ca. 1,100	1,600	1,900	700
	A/T**		4,400	4,000	3,400	1,000	ca. 1,100	1,600	1,900	700

* Fully automatic double batch system ** Fully automatic triple batch system with two work bowls (tandem)

ENGINEERED FOR HIGH PERFORMANCE AND LOW COSTS

- Work bowl and spinner geometry allow fluid, unobstructed movement of parts and media
- Infinitely adjustable water level in the work bowl for different process intensities
- Variable spinner speed with frequency inverter
- Automatic adjustment of the gap size via PLC! Gap size is adjustable within an accuracy of 0.01 mm
- Gap rinsing with the work bowl in unload position prevents premature wear of spinner and work bowl
- Anti blocking system prevents "fusing" between spinner and work bowl
- Monitoring of the temperature in the gap area with auto stop prevents damage to spinner and work bowl

TANDEM SYSTEMS

The tandem version consists of two processing units (work bowl/spinner combination) but only one intermediate hopper and separation unit. It offers significant advantages for applications requiring long finishing times but only short separation cycles: The finished batches from both processing units are – one after the other – transferred to the intermediate hopper/screening machine for separation of the finished parts from the media.

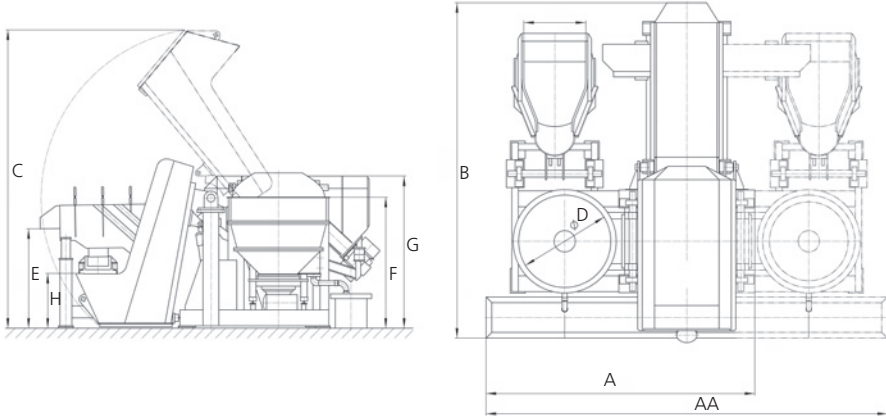

**WALTHER
TROWAL!**

Walther Trowal GmbH & Co. KG
Rheinische Straße 35-37 | D-42781 Haan
Tel. +49(0)2129-571-0 | Fax +49(0)2129-571-225
info@walther-trowal.com | www.walther-trowal.com